

Dunja MATULJA<sup>1</sup>

Marco SPORTELLI<sup>2</sup>

Carlos GUEDES SOARES<sup>2</sup>

Jasna PRPIĆ-ORŠIĆ<sup>1</sup>

## Estimation of Added Resistance of a Ship in Regular Waves

### Authors' Addresses (Adrese autora):

<sup>1</sup> Faculty of Engineering, Rijeka

<sup>2</sup> Instituto Superior Técnico, Lisbon, Portugal

Received (Priljeno): 2011-02-18

Accepted (Prihvaćeno): 2011-04-29

Open for discussion (Otvoreno za raspravu): 2012-10-01

*The following article is published in its integral version with all the illustrations included by the authors. In the September hard-copy issue of Brodogradnja journal the article will be published with a significantly reduced number of illustrations.*

*Editors*

*Priloženi članak na ovom mjestu se objavljuje u integralnom obliku sa svim ilustracijama koje je uvrstio autorski tim. U rujanskom klasičnom broju Brodogradnje članak će se tiskati sa znatno smanjenim brojem ilustracija.*

*Uredništvo*

Preliminary communication

Two methods of added resistance calculation are briefly presented, one developed by Faltinsen, and the other by Salvesen. Both are based on the Salvesen, Tuck and Faltinsen linear strip theory, as they use it to define the wave induced motions. The first one obtains the added resistance by direct pressure integration, while the second one involves the potential flow solution. Also, as a third method, an empirical approximation of the Salvesen method for the short wave lengths region is included.

The calculations of added resistance due to waves are performed according to the chosen methods for four different ships: two containerships, a bulk carrier and a ro-ro vessel. The results are presented graphically, with the comparison to experimental results for the available cases.

**Keywords:** *added resistance, motion of a ship in waves, speed loss.*

## Određivanje dodatnog otpora broda na pravilnim valovima

Prethodno priopćenje

U radu su ukratko izložene dvije metode, od kojih je jedna temelji na Faltinsenovom radu, a druga na Salvesenovom. Obje metode proizlaze iz Salvesenove, Tuckove i Faltinsenove linearne vrpčaste teorije, jer se pomoću nje određuju gibanja inducirana djelovanjem valova. Međutim, kod prve metode dodatni otpor dobiva se direktnom integracijom tlakova, dok se u drugoj rješava potencijalno strujanje. Osim ove dvije, radi usporedbe je uvedena i treća metoda, odnosno iskustvena aproksimacija Salvesenove metode za područje manjih valnih duljina.

Primjenom navedenih metoda, provedeni su proračuni dodatnog otpora zbog utjecaja valova za četiri različita broda: dva broda za prijevoz kontejnera, jedna brod za prijevoz rasutog tereta i jedan ro-ro. Rezultati su prikazani grafički, uz usporedbu s eksperimentalnim vrijednostima za dostupne slučajeve.

**Ključne riječi:** *dodatni otpor, gibanje broda na valovima, gubitak brzine*

# 1 Introduction

The capability to sustain speed in a seaway is one of the primary objectives in the design of marine vehicle. The added resistance of a ship in a seaway is becoming of great importance because of the increasing demand in transportation speed and voyage duration [1] as well as because of the increasing conscience of the need to reduce emissions from the ships [2].

The term “Added Resistance” is used to describe the phenomenon of energy loss because of generation of waves as a consequence of ship motions due to sea waves. To this purpose the ship resistance in calm water is increased by accounting for the effect of seaway. The ship speed, required power and propeller characteristics are usually estimated for still water conditions. But during its exploitation, the ship encounters different sea conditions and in many occasions the seaway influences the resistance and propulsion features. The added resistance of a ship in waves is generally explained by three effects: the so-called drifting force resulting from interference of incidence waves and waves generated by heaving and pitching; the damping force associated with heaving and pitching in calm water; the diffraction force due to the interference of waves and ship. These forces are related to the energy transmitted from the ship to the water and to wave generation. In general, it has been proved that the drifting force is the most significant, while the diffraction force would make the smallest contribution, more important for short waves. The viscous effect due to the damping of the vertical motions represents only a small part of this extra-induced loss of energy.

Progress made in seakeeping, in both analytical methods and experimental techniques, makes it possible to determine added resistance with sufficient accuracy for design purposes. However, the accuracy of added resistance calculation depends very much on the accuracy of ship motion prediction, but this problem will not be considered here. The same is valid for the effect of wind loads on speed loss and the effects which lead to intentional speed reduction based on the ship master’s judgment (such as slamming, propeller racing, ventilation, excessive accelerations and green water on the deck).

The phenomenon treated in the paper is the added resistance of a ship advancing in regular waves, which causes involuntary speed reduction. During voyage in wind and waves, the increase of the resistance requires an adequate power increase in order to maintain a certain cruising speed. The added resistance may also have significant influence on ship’s performance in moderate seas, especially for ships with blunt bow-forms. Therefore, a preliminary estimation of added resistance considering a given sea condition needs to be performed.

Different methods of added resistance estimation can be chosen, starting from the simplest empirical ones to the most recent computational methods [3]. Several theoretical methods of added resistance estimation can be pointed out: Havelock [4], Maruo [5], Joosen [6], Boese [7], Gerritsma and Beukelman [8]. These methods have been evaluated by different authors (Strom-Tejsen et al., [9]), and none of them seems to predict the added resistance accurately over a wide range of ship forms and speeds. Considering the disadvantages of each of these methods, two other methods have been developed, in order to allow the added resistance estimation for any ship type at any speed, and at any heading.

One has been developed by Faltinsen [10], and the other by Salvesen [11]. Both are based on the Salvesen, Tuck and Faltinsen linear strip theory [12], as they use it to define the wave induced motions. The first one obtains the added resistance by direct pressure integration, while the second one involves the potential flow solution. The idea of the paper is to briefly explain and compare these two methods. The coefficients obtained by the linear strip theory are used for the numerical calculation of the required pressures and forces, and

the added resistance due to waves is expressed non-dimensionally. The results are presented graphically, with the comparison to experimental results for the available cases.

## 2 Added resistance estimation

### 2.1 The linear strip theory

The Salvesen, Tuck and Faltinsen linear strip theory is common to both methods as a tool to find the wave induced motion.

The theory assumes the ship to have a slender hull form with lateral symmetry. The ship is advancing at a constant mean forward speed  $U$  in sinusoidal waves with an arbitrary heading. The translatory displacements in the  $x$ ,  $y$ , and  $z$  directions are  $\eta_1$  (surge),  $\eta_2$  (sway) and  $\eta_3$  (heave), and the angular displacement of rotational motion about the  $x$ ,  $y$ , and  $z$  axes are  $\eta_4$  (roll),  $\eta_5$  (pitch) and  $\eta_6$  (yaw) respectively, as shown in Figure 1.

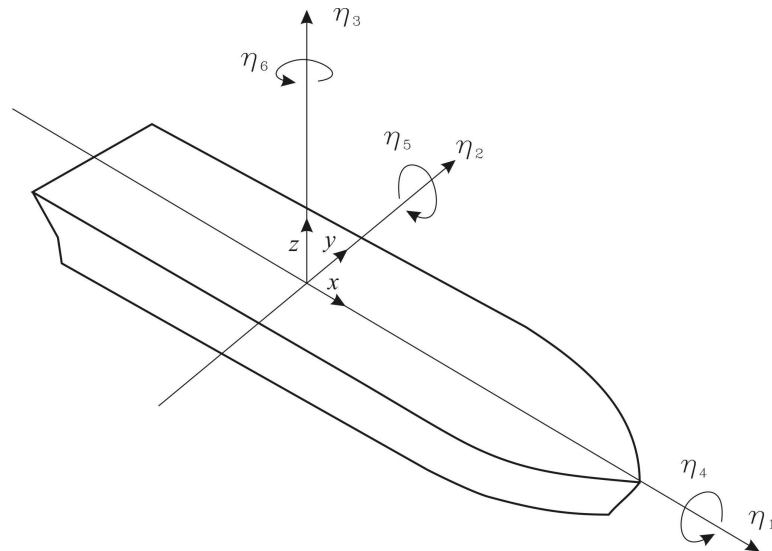

Figure 1 Ship motions  
Slika 1 Stupnjevi slobode gibanja

The responses are assumed to be linear and harmonic. The viscous effects are disregarded, so the fluid motions can be assumed as irrotational and the problem can be formulated within the potential flow theory.

The velocity potential for an incident wave, according to gravity theory, is:

$$\Phi_0(x, y, z; t) = \phi_0(x, y, z)e^{-i\omega_e t}, \quad (1)$$

$$\omega = \omega_e + kU \cos \beta. \quad (2)$$

Here  $k$  is the wave number and  $\beta$  is the heading angle.

At this point the complex amplitude of the incident wave potential can be expressed in terms of real and imaginary, and this is where the differences between the treated methods start.

In Faltinsen's method the linear wave induced motions and loads are calculated first. This way the dynamic pressures and dynamic elevations are obtained. The added resistance is then calculated by direct integration of the pressure over the wetted body surface.

What is particular is the setting of the coordinate system, which is right-handed and fixed with respect to the mean position of the ship. The origin is set in the plane of the undisturbed free surface, the  $z$  axis is positioned vertically upwards through the centre of gravity of the ship, while the  $x$  axis is in the aft direction.

Considering the Salvesen, Tuck and Faltinsen linear ship theory as a tool to find the wave induced motion, and the general assumptions made in the previous chapter, the Salvesen method can be briefly explained as it follows.

For this method, also based on the linear ship-motion theory, the coordinate system is right-handed and fixed with respect to the mean position of the ship. The origin is set in the plane of the free surface, the  $z$  axis is positioned vertically upwards through the centre of gravity of the ship, while the  $x$  axis is in the direction of forward motion.

In the linear strip theory, considering the coordinate system, the spatial incident wave potential can be defined as:

$$\phi_0 = \frac{ig\zeta_a}{\omega} e^{(-ik(x\cos\beta + y\sin\beta) + kz)} \quad (3)$$

where  $\zeta_a$  is the wave amplitude.

Considering the theory, for a slender ship with lateral symmetry, the two linear coupled equations that govern the heave and pitch motions in the frequency domain are:

$$\sum_{k=3,5} \left[ -\omega^2 (M_{jk} + A_{jk}) + i\omega B_{jk} + C_{jk} \right] \eta_k = F_j, \text{ for } j = 3 \text{ and } 5. \quad (4)$$

The exciting force and moment can be expressed as:

$$F_j = F_j^I + F_j^D \quad (5)$$

The term  $F_j^I$  represents Froude-Krilov force and moment, and  $F_j^D$  represents the diffraction force and moment.

## 2.2 Linear wave induced motions and loads

The time-dependent potential can be divided into three parts:

$$\phi_0(x, y, z) e^{-i\omega_e t} = \phi_I + \phi_F + \phi_D, \quad (6)$$

where  $\phi_I$  is the incident wave potential,  $\phi_F$  is the velocity potential due to forced motions in six degrees of freedom, and  $\phi_D$  is the diffraction potential of the restrained ship.

According to Faltinsen's method, after the analysis of each term, the time dependent velocity potential can be written as:

$$\phi_0 e^{-i\omega_e t} = \phi_I + \phi_2 \left( \eta_2 - \frac{i}{\omega_e} \bar{u}_y \right) + \phi_3 \left( \eta_3 - \frac{i}{\omega_e} \bar{u}_z \right) + \phi_4 \eta_4 + \left( -x + \frac{U}{i\omega_e} \right) \phi_3 \eta_5 + \left( x - \frac{U}{i\omega_e} \right) \phi_2 \eta_6 \quad (7)$$

In equation (7) the components  $\bar{u}_y$  and  $\bar{u}_z$  are:

$$\bar{u}_y = \omega \cdot \zeta_a \sin\beta \cdot e^{kz_m + ikx\cos\beta - i\omega_e t} \quad (8)$$

$$\bar{u}_z = -i\omega \cdot \zeta_a \cdot e^{kz_m + ikx \cos \beta - i\omega_e t} \quad (9)$$

In the equations (7) and (8)  $z_m$  is an average vertical cross-sectional coordinate, which can be chosen as  $-T/2$ , where  $T$  is the local draught.

The dynamic first order pressure at a fixed submerged point can be expressed as:

$$p = -\rho \left( \frac{\partial}{\partial t} + U \frac{\partial}{\partial x} \right) \phi_T e^{-i\omega_e t} \quad (10)$$

and the dynamic elevation  $\zeta$  can be written as:

$$\zeta = \frac{p}{\rho g} \Big|_{z=0} \quad (11)$$

### 2.3 Added resistance by pressure integration method

The pressure can be rewritten with the complete Bernoulli's equation, and a Taylor expansion of the pressure about the mean position of the ship can be made [10]. Since the wetted surface changes according to the wave amplitude, sink and trim, the pressure  $p_s$  on the ship corrected to second order in wave amplitude may then be written as:

$$\begin{aligned} p_s = & -\rho g z - \rho \left( \frac{\partial \phi^{(1)}}{\partial t} + U \frac{\partial \phi^{(1)}}{\partial x} \right)_m - \rho \left( \frac{\partial \phi^{(2)}}{\partial t} + U \frac{\partial \phi^{(2)}}{\partial x} \right)_m - \rho (\eta_2 + x\eta_6 - z\eta_4) \cdot \\ & \cdot \frac{\partial}{\partial y} \left( \frac{\partial \phi^{(1)}}{\partial t} + U \frac{\partial \phi^{(1)}}{\partial x} \right)_m - \rho (\eta_3 - x\eta_5 + y\eta_4) \frac{\partial}{\partial z} \left( \frac{\partial \phi^{(1)}}{\partial t} + U \frac{\partial \phi^{(1)}}{\partial x} \right)_m - \frac{\rho}{2} \left( \left( \frac{\partial \phi^{(1)}}{\partial x} \right)^2 + \right. \\ & \left. + \left( \frac{\partial \phi^{(1)}}{\partial y} \right)^2 + \left( \frac{\partial \phi^{(1)}}{\partial z} \right)^2 \right)_m + p_0 \end{aligned} \quad (12)$$

In this equation  $m$  indicates that the variables should be evaluated on the average position of the wetted ship hull. The contribution to the mean force from the pressure term  $\rho \left( \frac{\partial \phi^{(2)}}{\partial t} + U \frac{\partial \phi^{(2)}}{\partial x} \right)_m$  is shown to be zero, while by the integration of the other terms the added resistance force can be obtained:

$$\begin{aligned} \bar{F}_1 = & \int_c \left\{ -\frac{\rho g}{2} \bar{\zeta}_r^2 \right\} n_1 ds - \omega_e^2 M \overline{\eta_3 \eta_5} + \omega_e^2 M \overline{(\eta_2 - z_G \eta_4) \eta_6} \\ & + \rho \int_{S_B} \left\{ (\eta_2 + x\eta_6 - z\eta_4) \frac{\partial}{\partial y} \left( \frac{\partial \phi^{(1)}}{\partial t} + U \frac{\partial \phi^{(1)}}{\partial x} \right) \Big|_m + (\eta_3 - x\eta_5 + y\eta_4) \frac{\partial}{\partial z} \left( \frac{\partial \phi^{(1)}}{\partial t} + U \frac{\partial \phi^{(1)}}{\partial x} \right) \Big|_m \right. \\ & \left. + \left( \left( \frac{\partial \phi^{(1)}}{\partial x} \right)^2 + \left( \frac{\partial \phi^{(1)}}{\partial y} \right)^2 + \left( \frac{\partial \phi^{(1)}}{\partial z} \right)^2 \right) \right\} n_1 ds \end{aligned} \quad (13)$$

In this equation  $c$  represents the water line curve, and  $\bar{\zeta}_r = \bar{\zeta} - (\eta_3 - x\eta_5 + y\eta_4)$  is the relative motion along the ship, where  $\zeta$  indicates the wave elevation calculated by the linear theory, and the bar over the expressions means time-averaged values.

$S_B$  is the average wetted surface of the body.

## 2.4 The Salvesen method

From the previous considerations, Salvesen's formula for added resistance has been used as the basic tool of calculation:

$$R = -\frac{i}{2} k \cos \beta \sum_{j=3,5} \zeta_j \{F_j^{I*} + \hat{F}_j^D\} + R_7 \quad (14)$$

In this equation,  $F_j^{I*}$  is the complex conjugate of the Froude-Krilov part of the exciting force and moment, and  $\hat{F}_j^D$  is the same as the diffraction part of the exciting force  $F_j^D$ , except that in  $\hat{F}_j^D$  the complex conjugate of the incident wave potential,  $\phi_0^*$ , appears instead of  $\phi_0$ .

The conjugates of the Froude-Krilov exciting forces are:

$$F_3^{I*} = i\rho\omega \iint_S N_3 \phi_0^* dS \quad F_5^{I*} = -i\rho\omega \iint_S x N_3 \phi_0^* dS \quad (15)$$

The term  $\hat{F}_j^D$  is closely related to the diffraction force and moment  $F_j^D$  and is given by:

$$\hat{F}_3^D = \int_L \hat{h}_3(x) dx \quad \hat{F}_5^D = -\int_L \left( x + \frac{iU}{\omega_e} \right) \hat{h}_3(x) dx \quad (16)$$

With:

$$\hat{h}_3(x) = -\rho k \int_C \psi_3 (N_3 + i N_2 \sin \beta) \phi_0^* dl \quad (17)$$

$$R_7 = -\frac{1}{2} \zeta_a^2 \frac{\omega^2}{\omega_e} k \cos \beta \int_L e^{-2kds} (b_{33} + b_{22} \sin^2 \beta) dx \quad (18)$$

In the above equations  $N_2$  and  $N_3$  are the components in the  $y$  and  $z$  directions of the two-dimensional outward unit normal vector in the  $y, z$  plane,  $dl$  is an element of arc along the cross section  $C$  and  $\psi_3$  is the velocity potential for the two-dimensional problem of a cylinder oscillating in heave in the free surface. Furthermore,  $k$  is the wave number,  $d$  is the sectional draught and  $s$  the sectional-area coefficient.

Using the output files from the strip theory program however it is possible to evaluate  $F_j^D$  instead of  $\hat{F}_j^D$ , but from the equations (13) to (16) it seems that  $F_j^D \cong \hat{F}_j^D$  if  $U$  is high and  $\beta \cong 180^\circ$  or  $U$  is low and  $\beta \cong 90^\circ$ . This is confirmed by the obtained numerical results.

## 2.5 The Approximated – Salvesen method

Since the Salvesen method seems to give accurate results for the longer waves region ( $L/\lambda < 1.5$ ), a correction for the short wave lengths region has been made. The correction consists in an approximated formula proposed by Falinsen:

$$R = \frac{1}{2} \rho g \left( 1 + \frac{2\omega U}{g} \right) \int_{L_1} \sin^2 \vartheta n_1 dl \quad (19)$$

where:

$L_1$  is the non shadow zone of the water plane area

$n_1$  is the  $x$  component of the inward normal  $\mathbf{n}$  to the water line

$\vartheta$  is the angle between the tangent to the water line and the  $x$  axis (Figure 2).

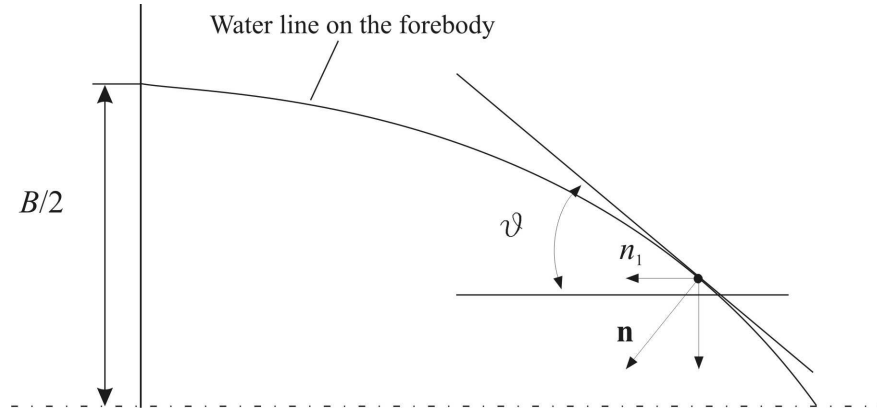

Figure 2 Illustration of  $n_1$  and  $\vartheta$

Slika 2 Prikaz vrijednosti  $n_1$  i  $\vartheta$

The idea is to use Faltinsen's approximated formula to evaluate wave reflection added resistance and then combine with Salvesen's results in a semi-empirical way. It must be pointed out that this is not a theoretical formulation for added resistance but just a "numerical tool".

The numerical results show that:

$$R = a \quad \text{for } L/\lambda \leq 1$$

$$R = a + b \quad \text{for } 1 < L/\lambda \leq 2 \quad (20)$$

$$R = b \quad \text{for } L/\lambda > 2$$

where:

$$a = -\frac{i}{2} k \cos \beta \sum_{j=3,5} \zeta_j \{ F_j^{I*} + \hat{F}_j^D \} \quad (21)$$

$$b = \frac{1}{2} \rho g \left( 1 + \frac{2\omega U}{g} \right) \int_{L_1} \sin^2 \vartheta n_1 dl \quad (22)$$

For the best accuracy,  $a$  must be evaluated for  $\beta \cong 180^\circ$  if  $U$  is high and for  $\beta \cong 90^\circ$  if  $U$  is low, but if the calculations are carried out for a certain heading, it is obvious that  $a$  cannot be evaluated differently for certain speeds in order to obtain better agreement of the results.

Furthermore, the term of “short waves region” can be somehow undefined, since it depends on the ship length. So, according to the ship’s geometry and speed, the expression  $R = b$  can be applied for  $L/\lambda > 1.5$  and give convincing results.

### 3 Comparison of the results

The calculations using both methods have been done for four ships: the ITTC containership *S-175* ( $L_{pp} = 175$  m,  $B = 25$  m,  $T = 9.5$  m,  $C_B = 0.60$ ), another containership, the *M/V ADEE* ( $L_{pp} = 117.6$  m,  $B = 20.2$  m,  $T = 8.3$  m,  $C_B = 0.653$ ), the *Grimaldi* Ro-Ro vessel ( $L_{pp} = 195.6$  m,  $B = 32.25$  m,  $T = 9.4$  m,  $C_B = 0.73$ ) and the bulk carrier *Stara Planina* ( $L_{pp} = 177$  m,  $B = 30$  m,  $T = 11.8$  m,  $C_B = 0.82$ ). Theoretical results obtained by the treated methods for the ITTC containership *S-175* are presented in Figures 3 to 6, and a comparison with the available experimental values is also given. The results for the *M/V ADEE* are reported in Figures 7 to 10, for the Ro-Ro in Figures 11 to 14, and for the bulk carrier in the Figures 15 to 18.

All the results are presented non-dimensionally, so the value  $R_{AW}$  represents the added resistance due to waves, reduced to a non-dimensional form by the following equation:

$$\frac{R_{AW}}{\rho \cdot g \cdot \zeta_a^2 \cdot B^2 / L} \quad (23)$$

The results are for different Froude numbers and wave lengths, while all the calculations have been done for head seas. As expected, all the methods predict the highest added resistance due to waves at the wavelength approximately equal to the ship length ( $L/\lambda = 1$ ). But, depending on the speed, the two theories show certain differences in the results. For lower speeds, the Faltinsen method predicts lower added resistance than the Salvesen method, while for higher speeds it predicts higher added resistance. The Faltinsen method seems to agree better with the known experimental results. The Salvesen method is not reliable for smaller wave lengths, therefore it is corrected by the approximated formula. This can be particularly noticed for the *M/V ADEE* results, where the discrepancy in the shorter waves region is still present despite the applied correction. For  $L/\lambda$  greater than 1.5 some inconsistencies can be noticed in the experimental results, as well in the results obtained by the Salvesen method, which seems to give significant changes of added resistance for a slight change of wave frequency in the mentioned range. For the first three considered ships the results follow the same trend, and the peak values differ within  $\pm 15\%$ , considering a mean value. But for the bulk carrier the results are quite inconsistent, and the cause of this inconsistency might be the form of the hull, which cannot be considered as slender. It has to be pointed out that for all the calculations the ship’s geometry has been described quite roughly, with a modest number of points, and the shape of the stem and stern are not taken into consideration. Therefore, complete precision cannot be expected, but the shape of the curves and the peak values can be taken as accurate enough.

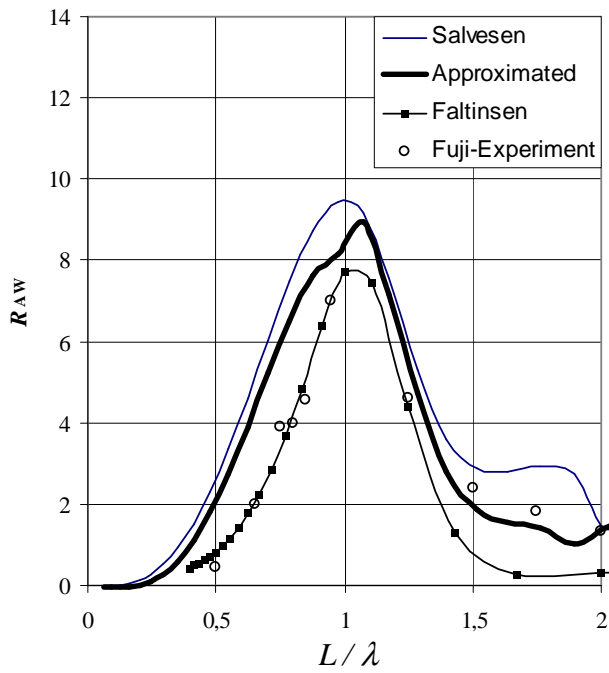

Figure 3 **Added resistance for S-175,  $Fr = 0.15$**   
 Slika 3 **Dodatni otpor za S-175,  $Fr = 0.15$**

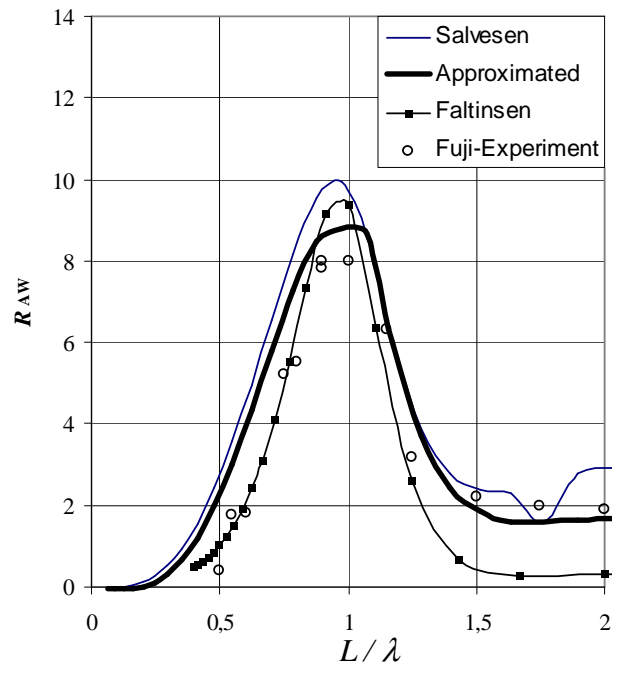

Figure 4 **Added resistance for S-175,  $Fr = 0.20$**   
 Slika 4 **Dodatni otpor za S-175,  $Fr = 0.20$**

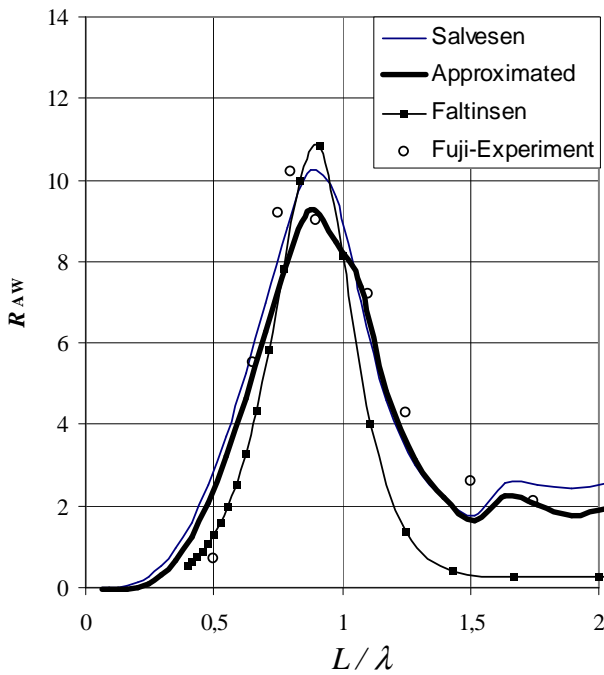

Figure 5 **Added resistance for S-175,  $Fr = 0.25$**   
 Slika 5 **Dodatni otpor za S-175,  $Fr = 0.25$**

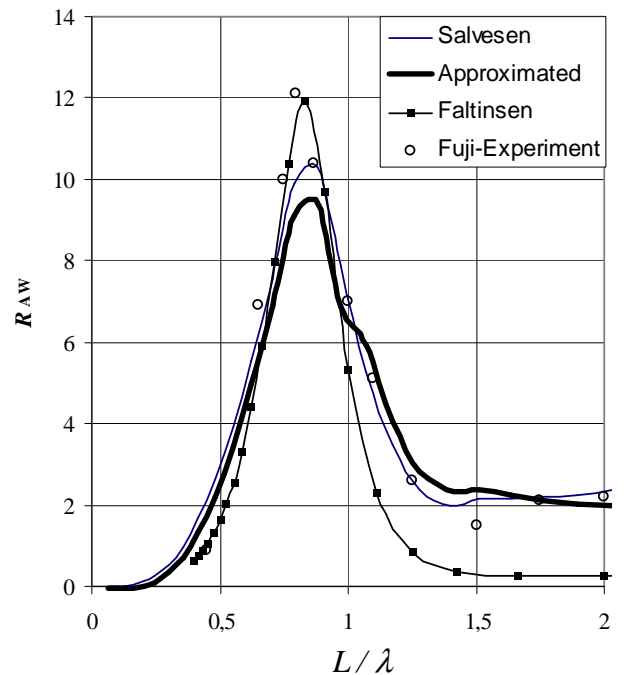

Figure 6 **Added resistance for S-175,  $Fr = 0.30$**   
 Slika 6 **Dodatni otpor za S-175,  $Fr = 0.30$**

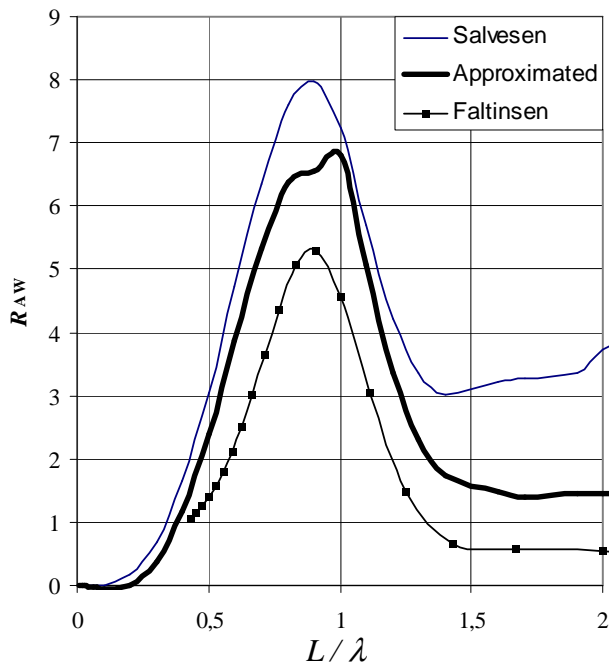

Figure 7 **Added resistance for M/V ADEE,  $Fr = 0.15$**   
 Slika 7 **Dodatni otpor za M/V ADEE,  $Fr = 0.15$**

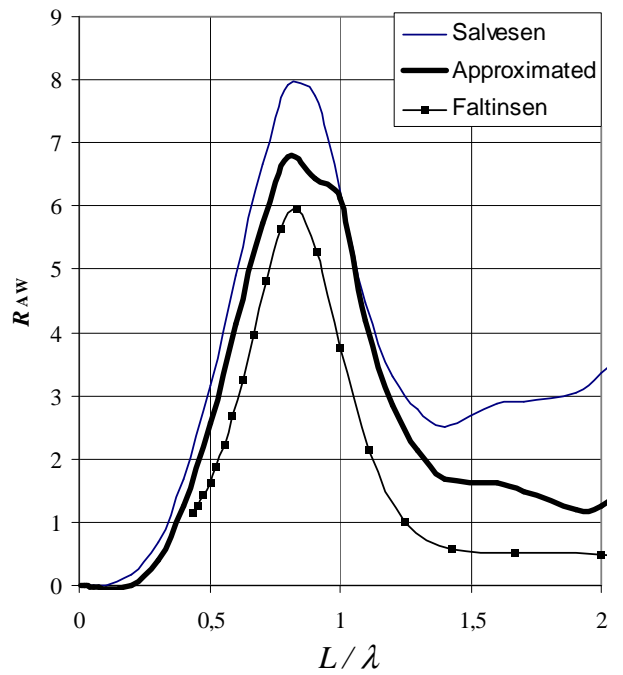

Figure 8 **Added resistance for M/V ADEE,  $Fr = 0.20$**   
 Slika 8 **Dodatni otpor za M/V ADEE,  $Fr = 0.20$**

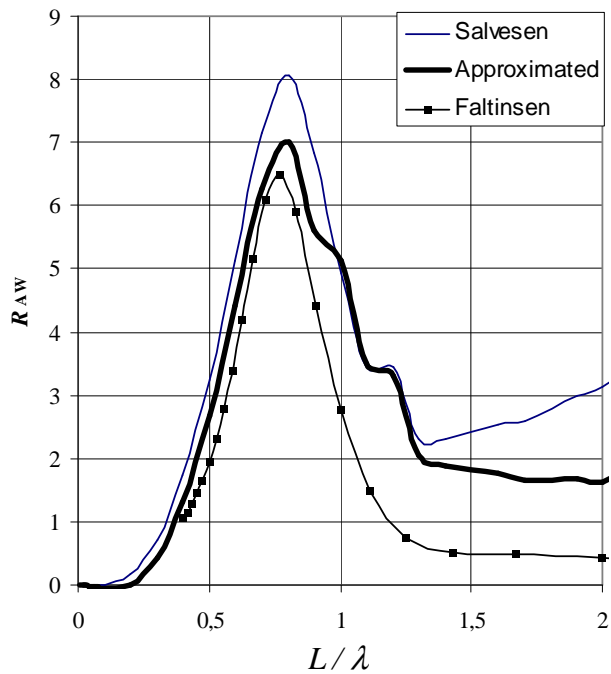

Figure 9 **Added resistance for M/V ADEE,  $Fr = 0.25$**   
 Slika 9 **Dodatni otpor za M/V ADEE,  $Fr = 0.25$**

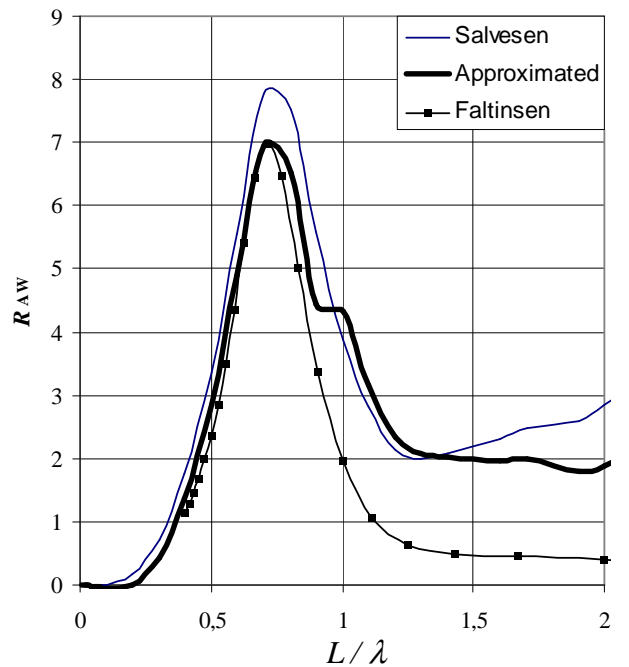

Figure 10 **Added resistance for M/V ADEE,  $Fr = 0.30$**   
 Slika 10 **Dodatni otpor za M/V ADEE,  $Fr = 0.30$**

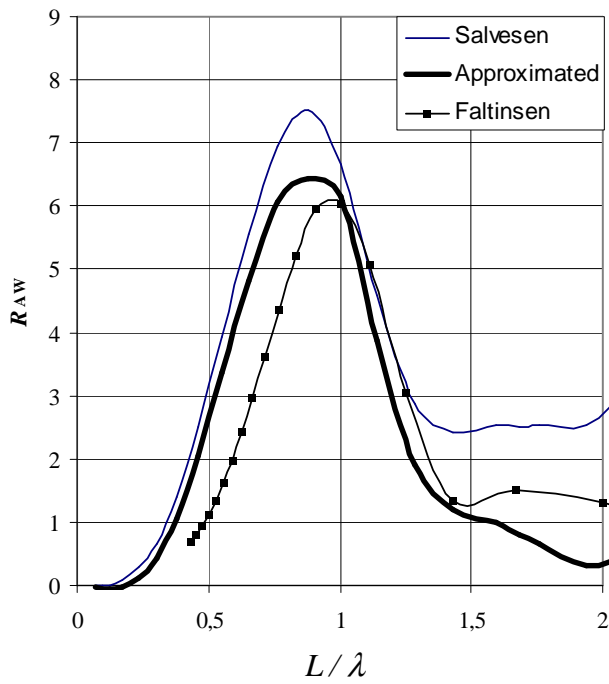

Figure 11 **Added resistance for Ro-Ro,  $Fr = 0.15$**   
 Slika 11 **Dodatni otpor za Ro-Ro,  $Fr = 0.15$**

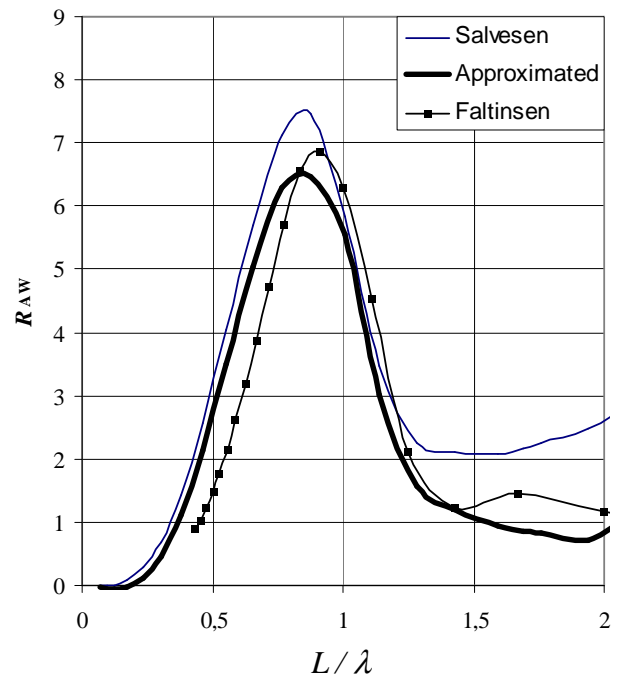

Figure 12 **Added resistance for Ro-Ro,  $Fr = 0.20$**   
 Slika 12 **Dodatni otpor za Ro-Ro,  $Fr = 0.20$**

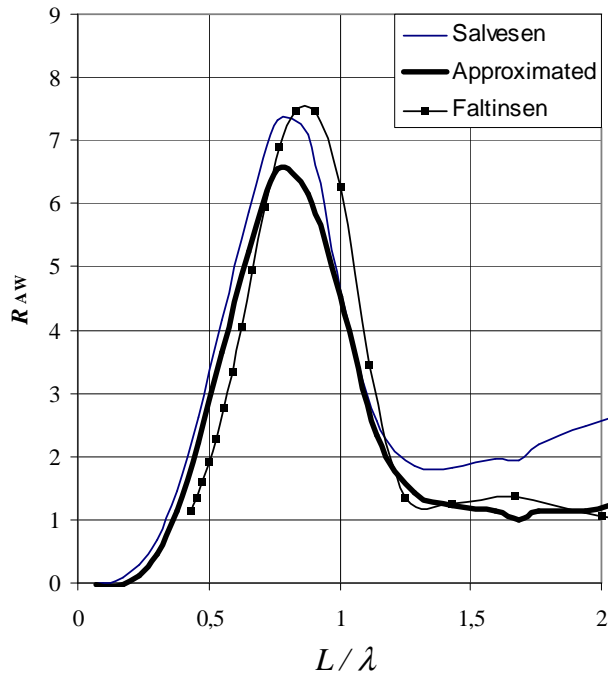

Figure 13 **Added resistance for Ro-Ro,  $Fr = 0.25$**   
 Slika 13 **Dodatni otpor za Ro-Ro,  $Fr = 0.25$**

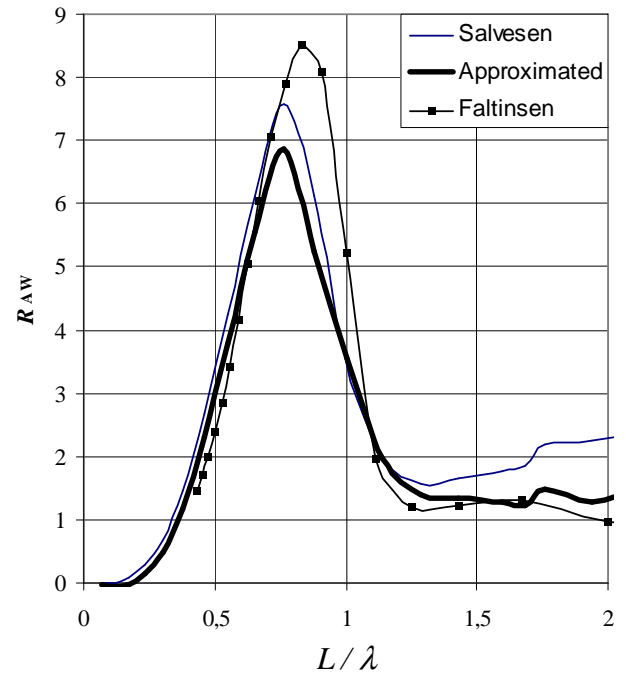

Figure 14 **Added resistance for Ro-Ro,  $Fr = 0.30$**   
 Slika 14 **Dodatni otpor za Ro-Ro,  $Fr = 0.30$**

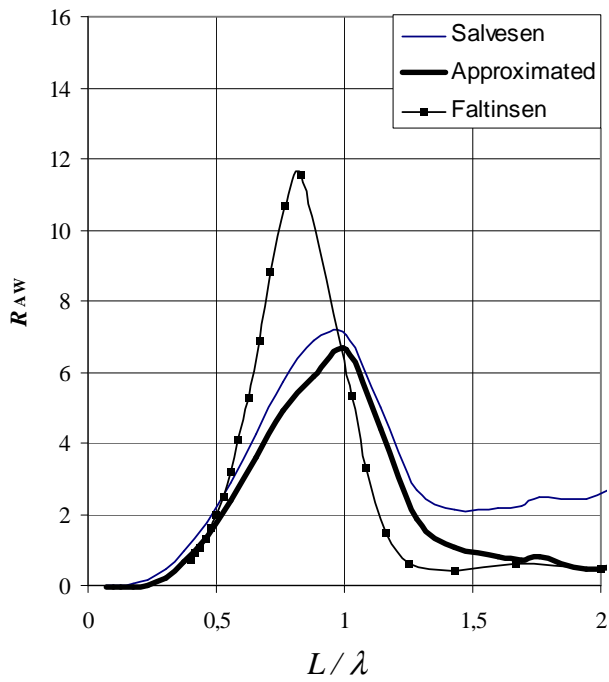

Figure 15 **Added resistance for Bulk Carrier,  $Fr = 0.15$**   
 Slika 15 **Dodatni otpor za Bulk Carrier,  $Fr = 0.15$**

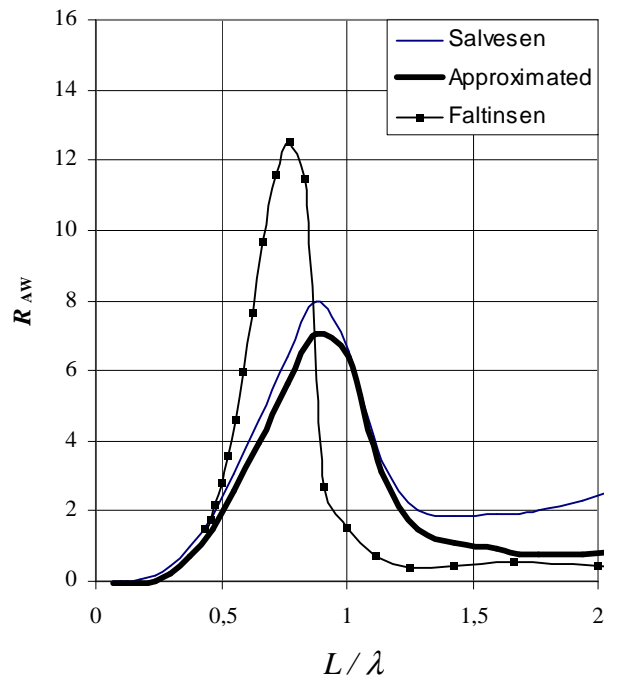

Figure 16 **Added resistance for Bulk Carrier,  $Fr = 0.20$**   
 Slika 16 **Dodatni otpor za Bulk Carrier,  $Fr = 0.20$**

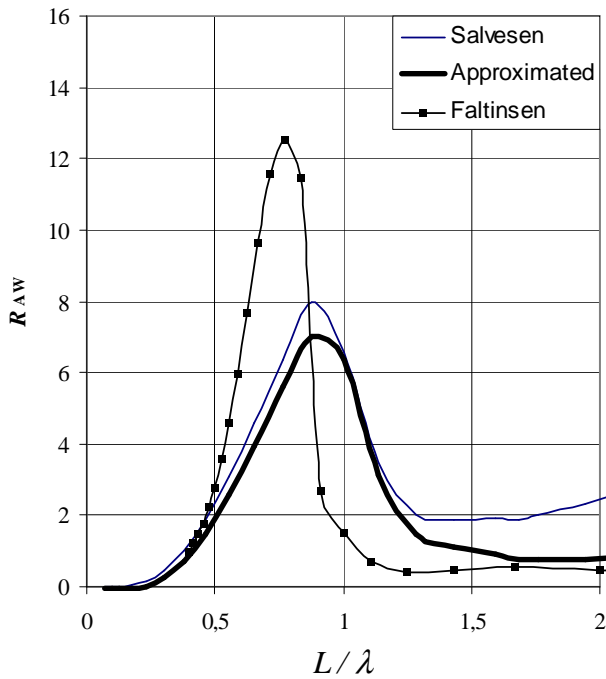

Figure 17 **Added resistance for Bulk Carrier,  $Fr = 0.25$**   
 Slika 17 **Dodatni otpor za Bulk Carrier,  $Fr = 0.20$**

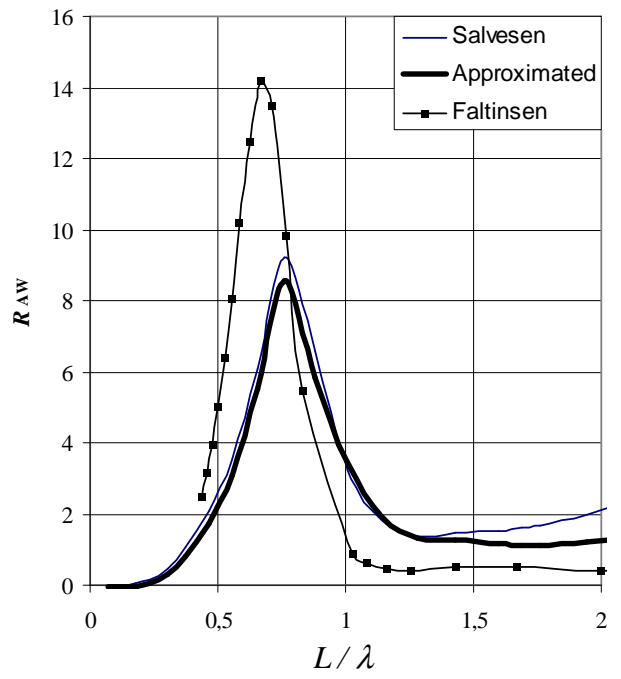

Figure 18 **Added resistance for Bulk Carrier,  $Fr = 0.30$**   
 Slika 18 **Dodatni otpor za Bulk Carrier,  $Fr = 0.20$**

## 4 Conclusion

A comparison of two methods for added resistance in regular waves has been presented: the Faltinsen method and the Salvesen method. Both methods are well known and widely used, with the exception of the approximation for lower wave lengths in the Salvesen method. Since the Salvesen method seems to overestimate the added resistance in the shorter waves region, this approximation has been applied as an attempt to improve its accuracy.

Since the basic theory of the methods is still being applied, a short overview of both is presented. The calculations are numerical, computed by codes written in Fortran and Matlab. Two containerships have been chosen for the calculations: the *SI75* and the *M/V ADEE*, as well as a bulk carrier and a Ro-Ro ship. The results are non-dimensional, and their absolute values of added resistance can be calculated. When available, a comparison with experimental results is also given. Both methods seem to predict the added resistance in head seas with similar accuracy in the longer waves region, except for the bulk carrier. This is not surprising because it is not a slender hull form, which is one of the basic assumptions of the theory. Therefore the results may be difficult to interpret. Also, the non-dimensional values of added resistance cannot illustrate their influence on total resistance in terms of total loss of speed or increase of power. A percentage value, considering the ship resistance in still water, would allow the prediction of the increase of power required to maintain the ship speed in the given conditions. The comparison between the required power for a ship advancing in still water and in a seaway is actually one of the basic targets of seakeeping calculations.

However, for a preliminary estimation of added resistance in regular waves any of the treated methods can be successfully used, since each of them provides the relevant data on the expected increase of resistance and on the conditions in which it occurs.

## Acknowledgements

Most of this work has been performed during a visit that the first author made to the Centre for Marine Technology and Engineering of *Instituto Superior Técnico* within the scope of the Project ASDEPP - Advanced Ship Design for Pollution Prevention, which was financed by the European Union through the TEMPUS Programme under the contract JEP-40037-2005.

## References

- [1] GUEDES SOARES, C., FONSECA, N., RAMOS, J.: "Prediction of Voyage Duration with Weather Constraints", Proceedings, International Conference on Motions and Manoeuvrability, Royal Institute of Naval Architects, London, 1998.
- [2] PRPIĆ-ORŠIĆ, J., FALTINSEN, O. M.: "Speed Loss Calculation in a Seaway, The 13<sup>th</sup> Congress IMAM 2009, Istanbul, Turkey, 2009.
- [3] PRPIĆ-ORŠIĆ, J., NABERGOJ, R., TRINCAS, G.: "The Methods of Added Resistance Estimation for Ships in a Seaway", Symposium Sorta 2008, Pula, Croatia, 2008.
- [4] HAVELOCK, T.H.: "Drifting Force on a Ship among Waves", *Philosophical Magazine* 33, 1942.
- [5] MARUO, H.: "The Excess Resistance of a Ship in a Rough Seas", *International Shipbuilding Progress* 4 (85), 1957.
- [6] JOSSEN, W.P.A.: "Added Resistance in Waves", 6<sup>th</sup> Symposium on Naval Hydrodynamics, Washington, 1966.

- [7] BOESE, P.: „Eine Einfache Methode zur Berechnung der Widerstandserhöhung eines Schiffes in Seegang“, Technical Report 258, Institut für Schiffbau der Universität Hamburg, 1970.
- [8] GERRITSMAN, J., BEUKELMAN, W.: “Analysis of the Resistance Increase in Waves of a Fast Cargo-Ship”, International Shipbuilding Progress 18 (217), 1972.
- [9] STROM-TEJSEN, J., YEH, H.Y.H., MORAN, D.D.: “Added Resistance in Waves”, SNAME 81, 1973.
- [10] FALTINSEN, O. M., MINSAAS, K. J., LIAPIS, N., SKJØRDAL, S.: “Prediction of Resistance and Propulsion of a Ship in a Seaway”, Proceedings of the 13<sup>th</sup> ONR Symposium, 1980.
- [11] SALVESEN, N. : “Added Resistance of Ships in Waves”, Journal of Hydronautics, 1978.
- [12] SALVESEN, N. TUCK, E.O. FALTINSEN, O. M.: “Ship Motions and Sea Loads”, SNAME, Jersey City, 1970.
- [13] FUJI, H., TAKAHASHI, T.: “Experimental Study on the Resistance Increase of a Ship in Regular Oblique Waves”, Proc. 14<sup>th</sup> ITTC, Vol. 4, p.351, 1975.
- [14] MATULJA, D., SPORTELLI, M., PRPIĆ-ORŠIĆ, J., GUEDES SOARES, C.: “Methods for Estimation of Ships Added Resistance in Regular Waves”, The 19th Symposium on Theory and Practice of Shipbuilding Sorta 2010.